

# SRG

## Schulz + Rackow Gastechnik GmbH

### SRG LPG Low Pressure Snap Tight Regulator Type 547

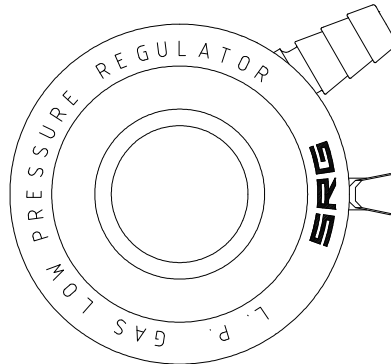
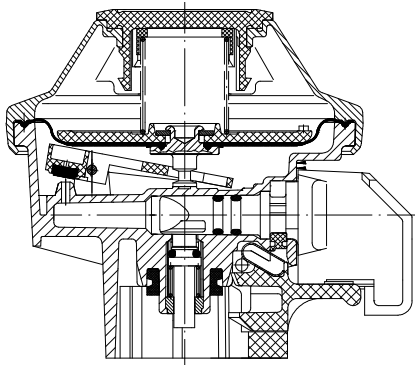

#### Technical Description

Inlet Connection	Outlet Connections
♦ 27 mm to EN 12864, fig. G.59	<ul style="list-style-type: none"> <li>♦ <b>Nozzle 8</b>, for hose with 8 mm inner dia., to EN 12864, fig. H.50</li> <li>♦ <b>Nozzle 10</b>, for hose with 10 mm inner dia., to EN 12864, fig. H.51</li> <li>♦ <b>other outlet connections available on request</b></li> </ul>
Outlet Pressure	Color
<ul style="list-style-type: none"> <li>♦ 28 mbar</li> <li>♦ 30 mbar</li> <li>♦ <b>other settings available on request</b></li> </ul>	<ul style="list-style-type: none"> <li>♦ <b>blue</b></li> <li>♦ <b>other colors available on request</b></li> </ul>

#### **Product Description:**

The SRG Snap Tight Regulator in connection with the SRG cylinder valve reduces the high gas pressure in the cylinder to the low service pressure. (Single stage regulation).

The body and cover of this regulator form a sealed unit after assembly in order to prevent any external interference which may affect the regulating mechanism.

The regulator can be equipped with a flow limiter which cuts off the gas flow automatically at approx. 1500 l air/hr. (under normal cylinder pressure) in case of a ruptured gas tubing or the gas tubing is pulled off. After cut-off the gas escape is limited to maximum 35 l air/hr.

Regulator inlet with additional shut-off valve for extra safety.

Regulators can be supplied with a reinforced diaphragm.

No tools are required to connect the regulator to the valve.

#### **Materials and Standards:**

The SRG Snap Tight Regulator is made of a zinc die casting (body and cover) and other corrosion-resistant and LPG-proof materials such as brass, stainless steel and acetal resin.

The rubber materials used are developed and produced according to the requirements of **EN 549** as well as in accordance with SRG's own stringent specifications.

#### **Quality standards:**

SRG's quality-control system carries an **ISO 9001** certificate and is continually assessed by the Notified Body.

#### **Capacity:**

Rated for inlet pressure of between 0,3 and 16 bar the regulator has a capacity of 1,0 kg gas/hr.

#### **Operation:**

Connection lever and on/off tap interlocked to ensure easy and safe handling:

- Connection is simple, by just pressing down
- Cannot be unintentionally disconnected.
- Switching on is possible only when the regulator is connected properly with the cylinder valve.

#### **Packaging:**

The SRG Snap Tight Regulator comes packed separately in a folding box. The folding boxes are packed in cardboard boxes.